

**TECHNICAL MANUAL**

**ORGANIZATIONAL MAINTENANCE REPAIR PARTS  
AND SPECIAL TOOLS LIST**

**FOR**

**CENTRAL OFFICE, TELEPHONE AUTOMATIC  
AN/TTC-41(V)5 (NSN 5805-01-044-8870),  
AN/TTC-41 (V)6 (NSN 5805-01-045-3157),**

**AND**

**AN/TTC-41 (V7 (NSN 5805-01-044-88711**

This copy is a reprint which includes current  
pages from Change 1.

CHANGE }  
No. 1 }

HEADQUARTERS  
DEPARTMENT OF THE ARMY  
WASHINGTON, DC, 2 July 1984

**Organizational Maintenance Repair Parts  
and Special Tools List**

**For  
CENTRAL OFFICE, TELEPHONE AUTOMATIC  
AN/TTC-41 (V)5 (NSN 5805-01-044 8870),  
AN/TTC-41 (V)6 (NSN 5805-01-045-3157),  
AND  
AN/TTC-41 (V)7 (NSN 5805-01-041 8871)**

TM 11-6805-693-20P-1, 18 January 1983, is changed as follow:

1. New or revised material is indicated by a vertical bar in the margin. Where an entire chapter, section, or illustration is added or revised, the vertical bar is placed opposite the identification number and title.
2. Remove old pages and insert new pages as follows:

<i>Remove pages</i>	<i>Insert pages</i>
i/(ii blank) .....	i/(ii blank)
1 through 12 .....	1, 2, and 3/(4 blank)
None .....	4.1 through 4.4
None .....	5 through 8
17 through 22 .....	17 through 22

3. File this change sheet in front of the publication

By Order of the Secretary of the Army:

JOHN A. WICKMAN JR.  
*General United States Army  
Chief of Staff*

Official:

ROBERT M. JOYCE  
*Major General, United States Army  
The Adjutant General*

DISTRIBUTION:

To be distributed in accordance with DA Form 12-51A-1 requirements for AN/TTC-41.

TECHNICAL MANUAL }  
 No. 11-5805-693-20P-1 }

HEADQUARTERS  
 DEPARTMENT OF THE ARMY  
 WASHINGTON, DC, 18 January 1983

**ORGANIZATIONAL MAINTENANCE REPAIR PARTS  
 AND SPECIAL TOOLS LIST**

**FOR**

**CENTRAL OFFICE, TELEPHONE AUTOMATIC**

**AN/TTC-41 (V)5 (NSN 5805-01-044-8870),**

**AN/TTC-41 (V)6 (NSN 5805-01-045-3157),**

**AND**

**AN/TTC-41 (V)7 (NSN 5805-01-044-8871)**

Basic Manual Current as of 25 August 1982

Change 1 current as of 29 May 1984

**REPORTING ERRORS AND RECOMMENDING IMPROVEMENTS**

You can help improve this manual if you find any mistakes or if you know of a way to improve the procedures, please let us know. Mail your letter, DA Form 2028 (Recommended Changes to Publications and Blank Forms), or DA Form 2028-2 located in the back of this manual direct to: Commander, US Army Communication-Electronics Command and Fort Monmouth, ATTN: DR-SEL-ME-MP, Fort Monmouth, NJ 07703. In either case, a reply will be furnished direct to you.

**Table of Contents**

SECTION	Page	Illus Figure
I	Introduction.....	1
II.	Repair Parts List.....	5
GROUP 00	Central Office Telephone, Automatic AN/TTC-41(V)5, (V)6, and (V)7	5 1
01	Trailer Communications Facility.....	7 2
	Flourescent Lamp Assemblies.....	13 3
	Intake Vent.....	15 4
	Patch Cords.....	17 5
	0101 Trailer Chassis M569 (See TM 9-2330-251-14 for parts)	
	0101 Equipment Rack (No parts authorized)	
	010201 AC Power Distribution Box (No parts authorized)	
	010202 DC Power Distribution Box.....	19 6
	010203 Signal Entrance Box (No parts authorized)	
	010204 Patch Panel (No parts authorized)	

		Page	Illus Figure
GROUP	01 010205 Top Assembly .....	21	7
	010206 Jack lifting Assembly (No parts authorized)		
	02 Exhaust Blower Assembly (No parts authorized)		
	03 Multifuel Heater UH-48C (See TM 5-4520-239-24P for parts)		
	04 Power Cable (50 Feet) CX-7453A/U (No parts authorized)		
	06 Power Cable Stub (15 Feet) CX-7705A (No parts authorized)		
	06 Switchboard, Automatic SB-3614/TT (See TM 11-6805-695-20P for parts)		
	07 Battery, Storage BB-501/U (Nickel Cadmium) (See TM 11-6140-203-20P-3 for parts)		
	08 Battery, Storage BB-2971U (Load Acid) (Se TM 9-6140-200-14 for parts)		
	09 Intercommunication Station LS-147F/FI (See TM 11-5830-256-23P for parts)		
	10 Telephone Set TA-838/TT (See TM 11-5805-650-12&P for parts)		
	10 1001 Mounting Brackets Telephone (No parts authorized)		
	11 Power Supply PP-6224/U (See TM 11-6130-266-15 for part)		
	12 Headset Microphone H-182/PT (See TM 11-5986-283-20P for parts)		
	13 Headset Switchbox (No parts authorized)		
SECTION	III. Special Tools List (Not applicable)		
SECTION	IV. National Stock Number and Part Number Index .....	22	

**SECTION I  
INTRODUCTION**

**1. Scope**

This manual lists spares and repair parts; special tools; special test, measurement, and diagnostic equipment (TMDE), and other special support equipment required for performance of organizational maintenance of the AN/TTC-41(V)5, 6 and 7. It authorizes the requisitioning and issue of spares and repair parts as indicated by the source and maintenance codes.

**2. General**

This Repair Parts and Special Tools List is divided into the following sections:

- a. Section II. Repair Parts List A list of spares and repair parts authorized for use in the performance of maintenance. The list also includes parts which must be removed for replacement of the authorized parts. Parts lists are composed of functional groups in numeric sequence, with the parts in each group listed in figure and item number sequence.
- b. Section III. Special Tools List Not applicable.
- c. Section IV. National Stock Number and Part Number Index. A list, in National item identification number (NIIN) sequence, of all National stock numbers (NSN) appearing in the listings, followed by a list, in alphanumeric sequence, of all part numbers appearing in the listings. National stock numbers and part numbers are cross-referenced to each illustration figure and item number appearance.

**3. Explanation of Columns**

a. Illustration. This column is divided as follows:

- (1) Figure number. Indicates the figure number of the illustration on which the item is shown.
- (2) Item number. The number used to identify item called out in the illustration.

b. Source, Maintenance, and Recoverability (SMU Codes).

(1) Source code. Source codes indicate the manner of acquiring support items for maintenance, repair, or overhaul of end items. Source codes are entered in the first and second positions of the Uniform SMR Code format as follows:

<i>Code</i>	<i>Definition</i>
PA-	Item procured and stocked for anticipated or known usage.
PD-	Support item, excluding support equipment, procured for initial issue or outfitting and stocked only for subsequent or additional initial issues or outfittings. Not subject to automatic replenishment.
XA-	Item is not procured or stocked because the requirements for the item will result in the replacement of the next higher assembly.
XB-	Item is not procured or stocked. If not available through salvage, requisition.

**NOTE**

Cannibalization or salvage may be used as a source of supply for any items source coded above except those coded XA and aircraft support items as restricted by AR 750-1.

(2) Maintenance code. Maintenance codes are assigned to indicate the levels of maintenance authorized to USE and REPAIR support items. The maintenance codes are entered in the third and fourth positions of the Uniform SMR Code format as follows:

(a) The maintenance code entered in the third position will indicate the lowest maintenance level authorized to remove, replace, and use the support item. The maintenance code entered in the third position will indicate one of the following levels of maintenance:

<i>Code</i>	<i>Application/Explanation</i>
O-	Support item is removed, replaced, used at the organizational level

(b) The maintenance code entered in the fourth positions indicates whether the item is to be repaired and identifies the lowest maintenance level with the capability to perform complete repair (i.e., all authorized maintenance functions). This position will contain one of the following maintenance codes:

<i>Code</i>	<i>Application/Explanation</i>
O-	The lowest maintenance level capable of complete repair of the support item is the organizational level
F-	The lowest maintenance level capable of complete repair of the support item is the direct support level
H-	The lowest maintenance level capable of complete repair of the support item is the general support level

*Code Application/Explanation*

D- The lowest maintenance level capable of complete repair of the support item is the depot level  
 Z- Nonreparable. No repair is authorized.

(3) *Recoverability code.* Recoverability codes are assigned to support items to indicate the disposition action on unserviceable items. The recoverability code is entered in the fifth position of the Uniform SMR Code format as follows:

*Recoverability*

*codes Definition*

Z- Nonreparable item. When unserviceable, condemn and dispose at the level indicated in position 3.  
 O- Repairable item. When uneconomically repairable, condemn and dispose at organizational level  
 F- Repairable item. When uneconomically repairable, condemn and dispose at the direct support level  
 H- Repairable item. When uneconomically repairable, condemn and dispose at the general support level  
 D- Repairable item. When beyond lower level repair capability, return to depot. Condemnation and disposal not authorized below depot level  
 A- Item requires special handling or condemnation procedures because of specific reasons (i.e., precious metal content, high dollar value, critical material or hazardous material). Refer to appropriate manuals/directives for specific instructions.

c. *National Stock Number.* Indicates the National stock number assigned to the item and will be used for requisitioning purposes.

*d Federal Supply Code for Manufacturer (FSCM).*

The FSCM is a 5-digit numeric code listed in SB 708-41/42 which is used to identify the manufacturer, distributor, or Government agency, etc.

e. *Part Number.* Indicates the primary number used by the manufacturer (individual, company, firm, corporation, or Government activity), which controls the design and characteristics of the item by means of its engineering drawings, specifications, standards, and inspection requirements to identify an item or range of items.

**NOTE**

When a stock numbered item is requisitioned, the repair part received may have a different part number than the part being replaced.

f. *Description.* Indicates the Federal item name and, if required, a minimum description to identify the item.

g. *Unit of Measure (U/M).* Indicates the standard of the basic quantity of the listed item as used in performing the actual maintenance function. This measure is expressed by a two character alphabetical abbreviation (e.g., ea, in, pr, etc). When the unit of measure differs from the unit of issue, the lowest unit of issue that will satisfy the required units of measure will be requisitioned.

h. *Quantity Incorporated in Unit.* Indicates the quantity of the item used in the breakout shown on the illustration figure, which is prepared for a functional group, subfunctional group, or an assembly.

4. Special Information

a. Usable on codes are shown in the description column Uncoded items are applicable to all models. Identification of the usable on codes used in this publication are:

<i>Code</i>	<i>Used on</i>
DJQ	AN/TTC-41(V)5
DJR	AN/TTC-41(V)6
DJS	AN/TTC-41(V)7

b. The following publications pertain to the AN/TTC-41(V)5, 6 and 7 and its components:

- TM 5-4520-239-14, Heater, Space, Multifuel, With Blower, 15,000 BTUIHR, 28 VDC (Hunter ModelsUH-48C, Type 1)
- TM 5-4520-239-24P, Heater, Space, Multifuel, With Blower, 15,000 BTUIHR, 28 VDC (Hunter Models UH-48C, Type 1) TM 9-2330-202-14P, Trailer, Cargo, 3/4 Ton, 2-Wheel M101 and MIOIA1; Chassis, Trailer, ¾ Ton, 2-Wheel M116 and M116A
- TM 9-2330-251-14, Trailer, Cargo, 1/4-Ton, 2-Wheel, M416, M416B1; Trailer, Chassis, 1/4-Ton, 2-Wheel, M569, 569B1; 3/4-Ton, 2-Wheel, M762 and Trailer, Cable Splicer, 1/4-Ton, 2-Wheel, M416A1
- TM 9-6140-200-14, Lead-Acid Storage Batteries; 4HN, 24V, MS75047-1, 2HN, 12V, MS35000-1, 6TN, 12V, MS35000-3
- TM 11-5805-650-12&P, Telephone Set TA-838/TT
- TM 11-5805-693-12-1, Central Office, Telephone Automatic AN/TTC-41(V)5, AN/TTC-41(V)6, and ANITTC-41(V)7
- TM 11-5805-695-12, Switchboard, Telephone SB-3614/TT
- TM 11-5805-695-20P, Switchboard, Telephone SB-3614/TT
- TM 11-5830-256-13&P, Intercommunication Station LS-147F/FI

TM 11-5830-256-23P, Intercommunication Station LS-147F/FI  
 TM 11-5935-205-14P, Connectors, Receptacle, Electrical U-187/G and U-187A/G  
 TM 11-5935-212-13P, Connectors, Plug, Electrical U-185A/G and U-185B/G  
 TM 11-5965-283-15, Headset-Microphone H-182/PT  
 TM 11-5965-283-20P, Headset-Microphone H-182/PT  
 TM 11-6130-266-15, Power Supply PP-6224/U and PP-6224A/U  
 TM 11-6140-203-14-3, Nonaircraft Nickel-Cadmium Batteries  
 TM 11-6140-203-20P-3, Nonaircraft Nickel-Cadmium Batteries BB-422/U, BB-651/UIH6(V), BB-429/U, BB-501/U, BB-693/U and BB-651/U

c. National stock numbers (NSN's) that are missing from P source coded items have been applied for and will be added to this TM by future change/revision when they are entered in the Army Master Data File (AMDF). Until the NSN's are established and published, submit exception requisitions to: Commander, US Army Communications-Electronics Command and Fort Monmouth, ATTN: DR-SEL-MM, Fort Monmouth, NJ 07703 for the part required to support your equipment.

d The illustrations in this manual are identical to those published in TM 11-5805-693-34P-1. Only those parts assigned the third position SMR maintenance code "C" or "O" are listed in the tabular listing; therefore, there may be a break in the item number sequence. Only illustrations containing organizational authorized items appear in this manual

e. Action change codes indicated in the left-hand margin of the listing page denote the following:

N--Indicates an added item.

C--Indicates a change in data.

R--Indicates a change in NSN only.

## 5. How to Locate Repair Parts

a. When National stock number or part number is unknown.

(1) *First* Using the table of contents, determine the functional group within which the item belongs. This is necessary since illustrations are prepared for functional groups and listings are divided into the same groups.

(2) *Second* Find the illustration covering the functional group to which the item belongs.

(3) *Third* Identify the item on the illustration and note the illustration figure and item number of the item.

(4) *Fourth*. Using the Repair Parts Listing, find the figure and item number noted on the illustration.

b. When National stock number or part number is known

(1) *First*. Using the index of National Stock Numbers and Part Numbers, find the pertinent National stock number or part number. This index is in NIIN sequence followed by a list of part numbers in alphanumeric sequence, cross-referenced to the illustration figure number and item number.

(2) *Second*. After finding the figure and item number, locate the figure and item number in the repair parts list.

## 6. Abbreviations

Not applicable.

(Next printed page is 4.1)

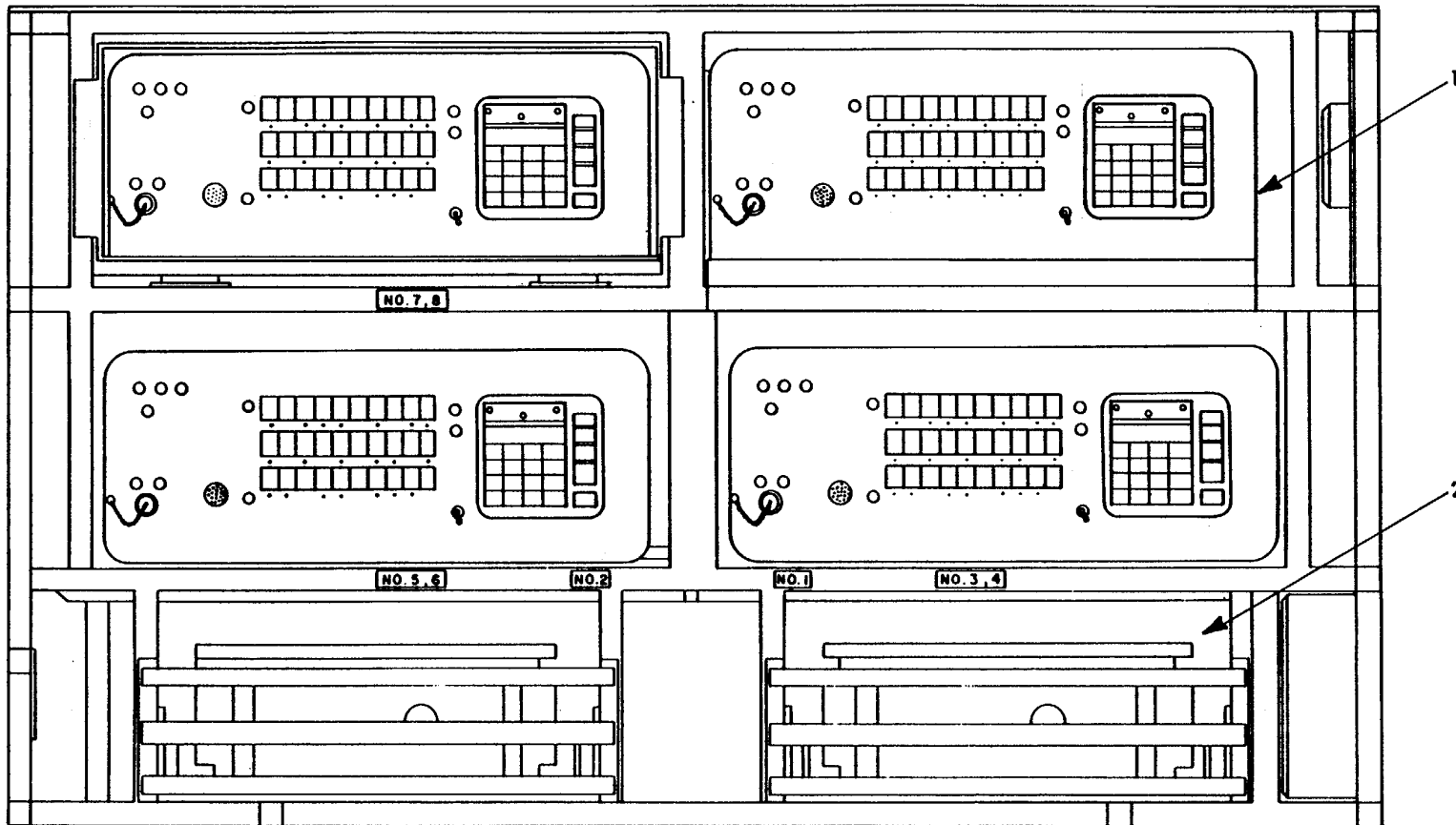

51501000

Figure 1. Central Office Telephone Automatic AN/TTC-41(V)5, (V)6 and (V)7 (Sheet 1 of 4).

Change 1 4.1



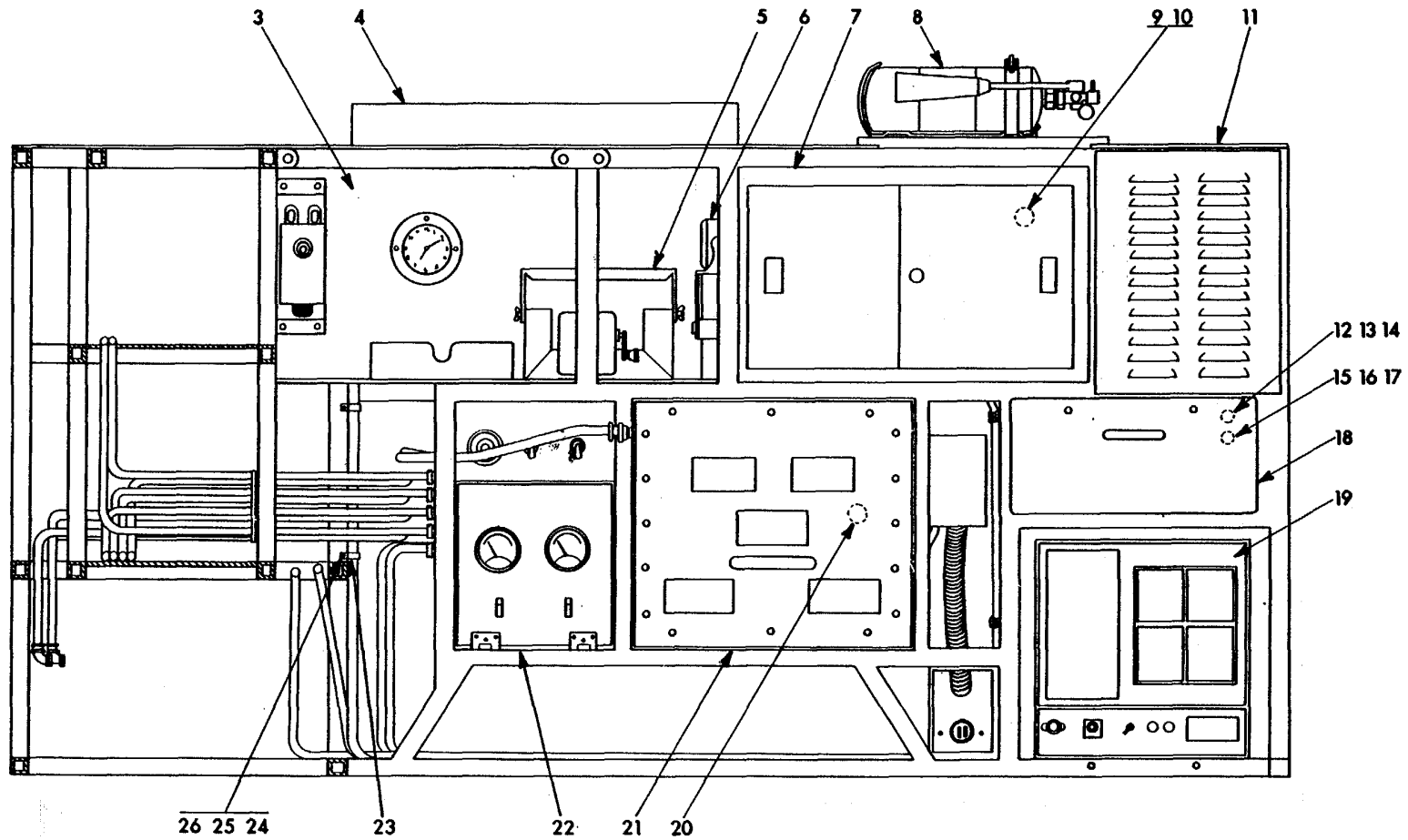

EL5S1003

Figure 1. Central Office Telephone Automatic AN/TTC-41(V)5, (V)6 and (V)7 (Sheet 2 of 4).

Change 1 4.2

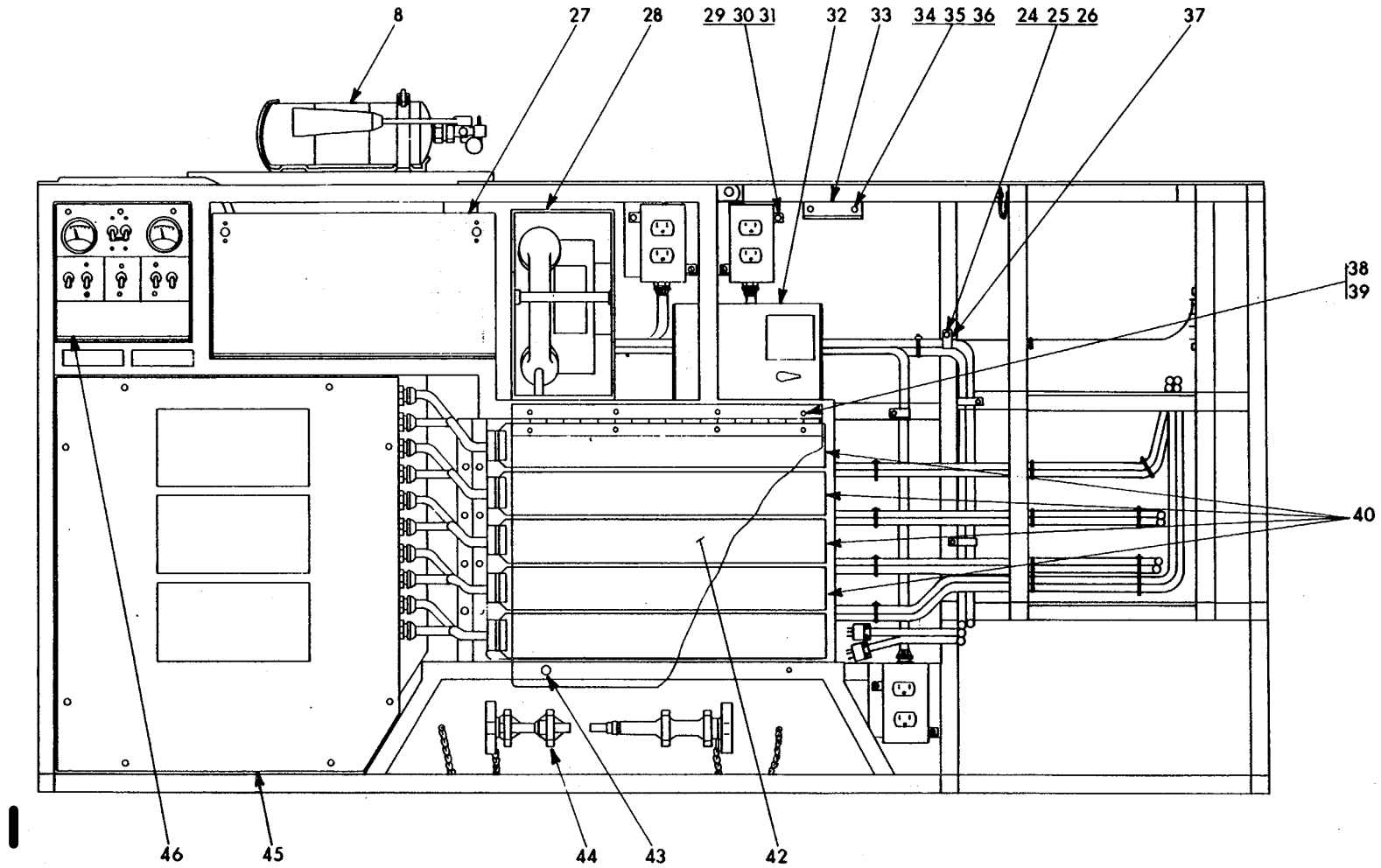

EL5SJ004

Figure 1. Central Office Telephone Automatic AN/TTC-41(V)5, (V)6 and (V)7 (Sheet 3 of 4).

Change 1 4.3

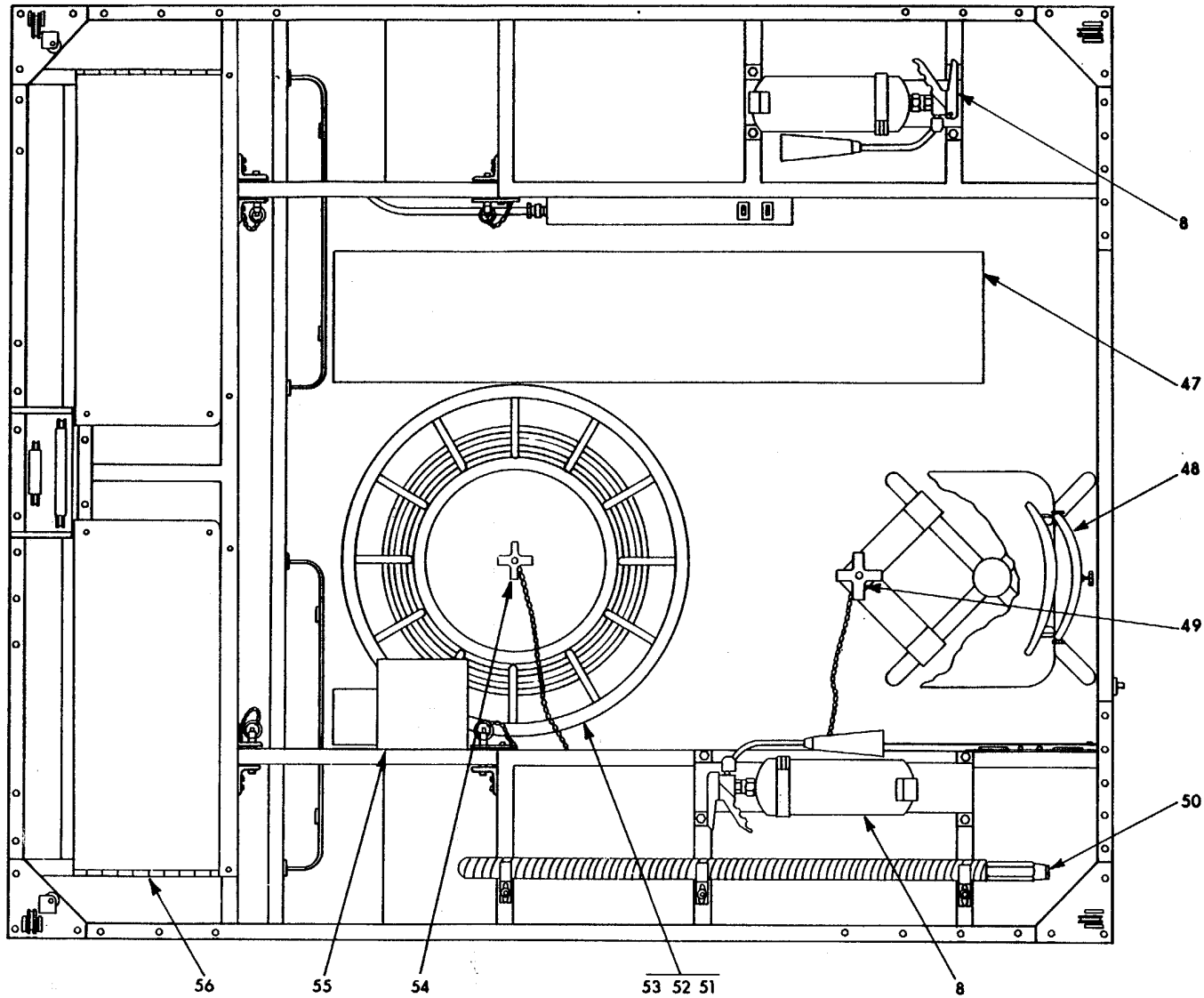

EL5S1005

Figure 1. Central Office Telephone Automatic AN/TTC-41(V)5, (V)6 and (V)7 (Sheet 4 of 4).

(1) ILLUSTRATION		(2)	(3)	(4)	(5)	(6)	(7)	(8)
(a) FIG NO.	(b) ITEM NO.	SMR CODE	NATIONAL STOCK NUMBER	FSCM	PART NUMBER	DESCRIPTION  <i>USABLE ON CODE</i>	U/M	QTY INC IN UNIT
						GROUP 00 CENTRAL OFFICE TELEPHONE AUTOHATIC AN/TTC-41(v)S THRU (V)7		
N	1	1	PDODD 5805-01-032-1694	80058	S-3614(Y)/TT	SWITCHBOARD,TELEPHONE..... DJQ	EA	2
N	1	1	PDODO 5805-01-032-1694	80058	SB-3614(V)/TT	SWITCHBOARD,TELEPHONE .....DJR	EA	3
N	1	1	PDODD 5805-01-032-1694	80058	SB-3614(V)/TT	SWITCHBOARD,TELEPHONE..... DJS	EA	4
N	1	2	POOHH 6130-00-133-5879	80058	PP-6224/U	POWER SUPPLY .....DJ1,DJR	EA	1
N	1	2	PDOHH 6130-00-133-5879	80058	PP-6224/U	POWER SUPPLY ..... DJS	EA	2
N	1	5	XBOZZ	80063	SC-D-681425	KIT FIRST AID .....	EA	1
N	1	6	PAOZZ 6230-00-729-9614	32572	2106-7	FLASHLIGHT.....	EA	1
N	1	8	PAOZZ 4210-00-555-8837	80063	SC-0-931429	EXTINGUISHER.FIRE,M.....	EA	2
N	1	10	PAOZZ 7920-00-178-8315	94322	09502210	BRUSH.DUSTING,BENCH.....	EA	1
N	1	12	PAOZZ 6630-00-171-4467	81348	GGT258CLISTYLEB	TESTER BATTERY .....	EA	1
N	1	14	PAOZZ	81348	GGGW631TYPEICLI SIZE 8	WRENCH ADJUSTABLE.....	EA	1
N	1	16	POOZZ 5965-00-069-8885	80058	H-182/PT	HEADSET-MICROPHONE.....DJQ,DJR	EA	2
N	1	16	POOZZ 5965-00-069-8885	80058	H-182/PT	HEAOSET-MICROPHONE..... DJS	EA	3
N	1	17	XAOZZ	07395	775090A0137-11	EXTRACTOR ELEC CARD..... DJQ	EA	1
N	1	19	PAOHH	81349	NILH52204TYPEI	HEATER SPACE MF .....	EA	1
N	1	20	PAOZA 6140-00-059-3528	96906	NS75047-1	BATTERY,STORAGE .....DJQ,DJR	EA	1
N	1	20	PAOZA 6140-00-059-3528	96906	NS75047-1	BATTERY,STORAGE ..... DJS	EA	2
N	1	28	PDOFF 5805-00-124-8678	80058	TA-838/TT	TELEPHONE SET .....	EA	2
N	1	32	PDOFF 5830-01-008-3126	80058	LS-147F/FI	INTERCOMMUNICATION..... DJQ	EA	1
N	1	47	XB0ZZ	80063	SCC539500-2	HAT,FLOOR. ....	EA	1
N	1	48	XBOZZ	81348	AAC295CL2SIZE2	CHAIR ROTARY .....	EA	1
N	1	51	PAOHH 5995-00-134-7159	80063	SH-0-352142	CABLE ASSEMBLY ANOD.....	EA	1

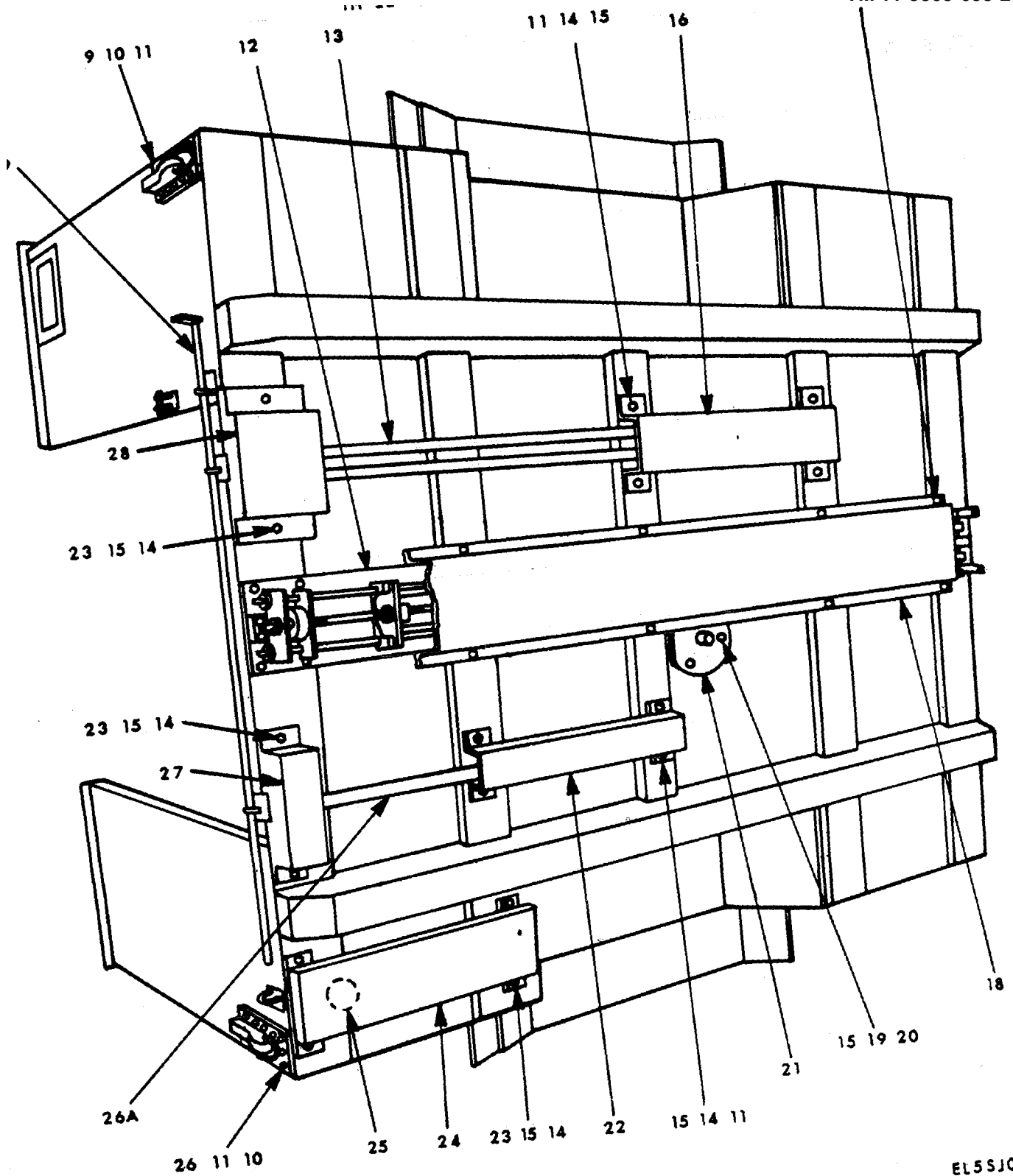
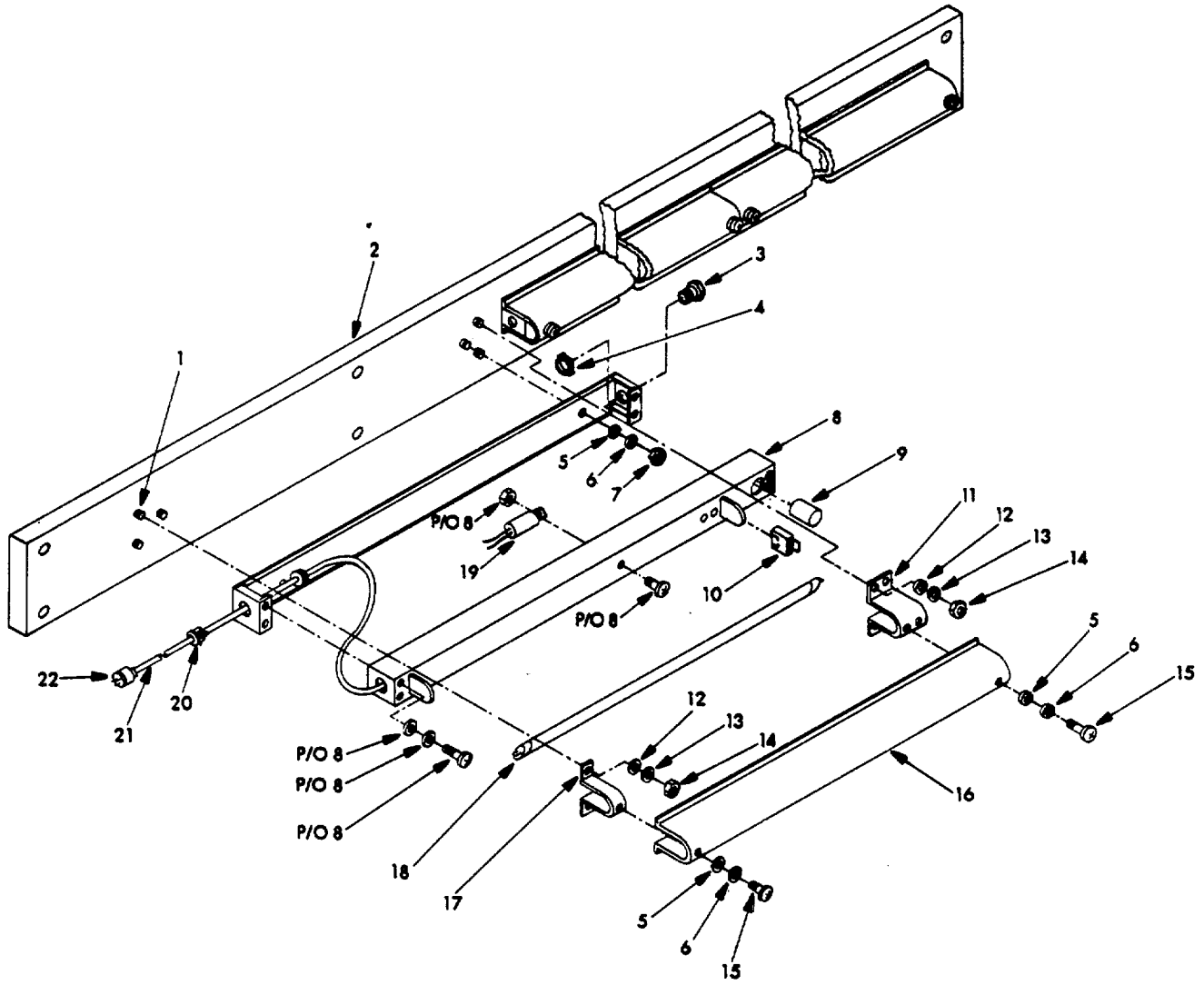

Figure 2. Trailer Communications Facility.

SECTION II

TM 11-5805-693-20P-1

(1) ILLUSTRATION		(2) SMR CODE	(3) NATIONAL STOCK NUMBER	(4) FSCM	(5) PART NUMBER	(6) DESCRIPTION  <i>USABLE ON CODE</i>	(7) U/M	(8) QTY INC IN UNIT
(a) FIG NO.	(b) ITEM NO.							
N N N	2	10	PAOZZ	5975-00-224-5260	80058	MX-143/G		
	2	25	PAOZZ	5120-01-127-5248	80063	SC-D-931238		
	2	26A	PAODD	5120-00-110-9193	80063	SC-D-539505		
						GROUP 01 TRAILER COMMUNICATIONS FACILITY		
						ROD, GROUND .....	EA	2
						WRFNCH SPEED.....	EA	1
						HAMMER, HAND .....	EA	1



EL5SJ006

NOTE: All material on pages  
9 through 12 deleted.

Figure 3. Fluorescent Lamp Assemblies.

(1) ILLUSTRATION		(2)	(3)	(4)	(5)	(6)	(7)	(8)
(a) FIG	(b) ITEM NO.	SMR CODE	NATIONAL STOCK NUMBER	FSCM	PART NUMBER	DESCRIPTION  <i>USABLE ON CODE</i>	U/M	QTY INC IN UNIT
NO.								
3	9	PAOZZ	6250-00-19-4794	81348	WS755 TYPE1 CLASS B	STARTER,FLUORESCEN.....	EA	3
3	18	PAOZZ	620-00-152-2982	08805	F15TBCW	LAMP,FLUORESCENT.....	EA	3



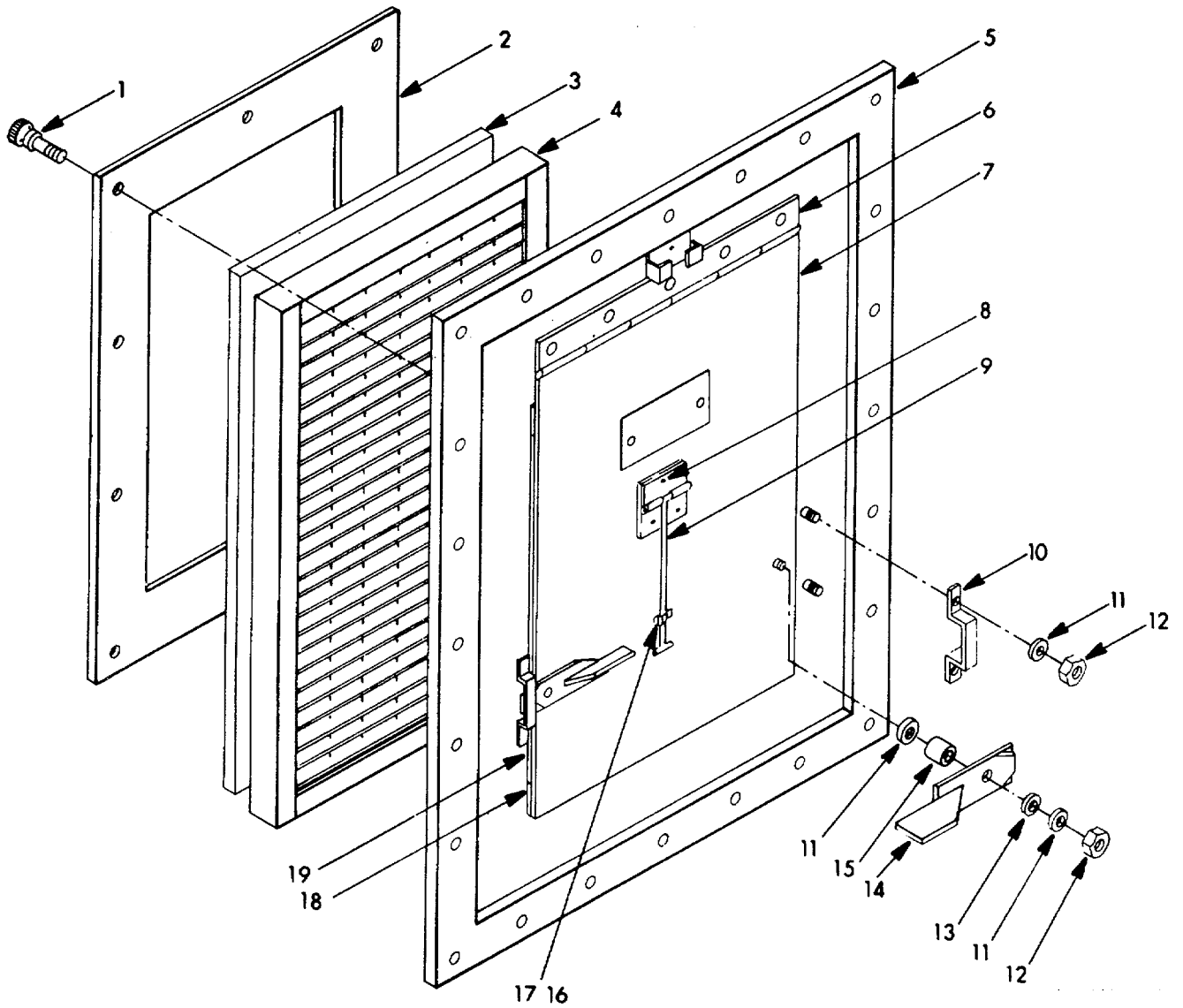

EL5SJ008

Figure 4. Intake Vent.

## SECTION II

TM 11-5805-693-20P-1

(1) ILLUSTRATION		(2)	(3)	(4)	(5)	(6)	(7)	(8)
(a) FIG NO.	(b) ITEM NO.	SMR CODE	NATIONAL STOCK NUMBER	FSCM	PART NUMBER	DESCRIPTION  <i>USABLE ON CODE</i>	U/M	QTY INC IN UNIT
	3	XAOZZ		80063	SC-C-931547	FILTER AIR INTAKE.....	EA	2

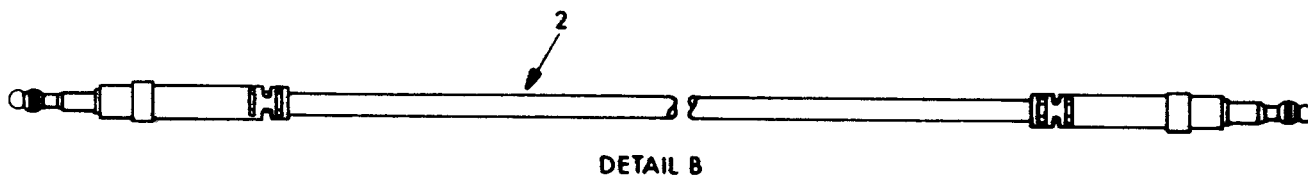
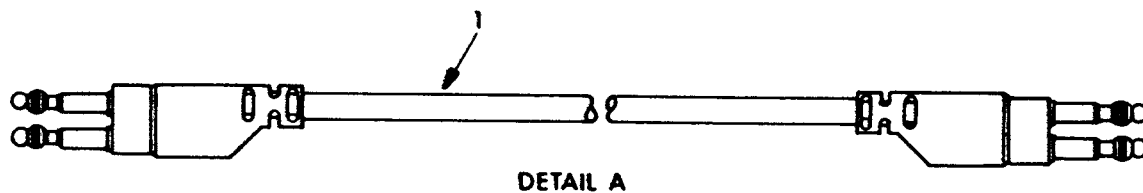

**EL5SJ007**

Figure 5. Patch Cords.

## SECTION II

TM 11-5805-693-20P-1

(1) ILLUSTRATION		(2)	(3)	(4)	(5)	(6)	(7)	(8)
(a) FIG NO.	(b) ITEM NO.	SMR CODE	NATIONAL STOCK NUMBER	FSCM	PART NUMBER	DESCRIPTION  <i>USABLE ON CODE</i>	U/M	QTY INC IN UNIT
5	1	PAOZZ	5995-00-319-8886	80063	SC-C-865810-1	PATCH CORD,DBL PLUG,6",PJ-761 .....	EA	8
5	1	PAOZZ	5995-00-241-7489	80063	SC-C-865810-2	PATCH CORD,DBL PLUG,12",PJ-762 .....	EA	10
5	1	PAOZZ	5995-01-096-4562	80063	SC-C-865810-3	PATCH CORD,DBL PLUG,18",PJ-763 .....	EA	8
5	1	PAOZZ	5995-00-102-1494	80063	SC-C-865810-4	PATCH CORD,DBL PLUG,24",PJ-764 .....	EA	4
5	1	PAOZZ	5995-00-441-9139	80063	SC-C-865810-5	PATCH CORD,DBL PLUG,30",PJ-765 .....	EA	3
5	2	PAOZZ	5995-00-113-0969	80063	SC-C-865811-1	PATCH CORD,SGL PLUG,6",PJ-711 .....	EA	15
5	2	PAOZZ	5995-00-717-9887	80063	SC-C-865811-2	PATCH CORD,SGL PLUG,12",PJ-712 .....	EA	20
5	2	PAOZZ	5995-00-041-3535	80063	SC-C-865811-3	PATCH CORD,SGL PLUG,18",PJ-713 .....	EA	15
5	2	PAOZZ	5995-00-998-0924	80063	SC-C-865811-4	PATCH CORD,SGL PLUG,24",PJ-714 .....	EA	8

R

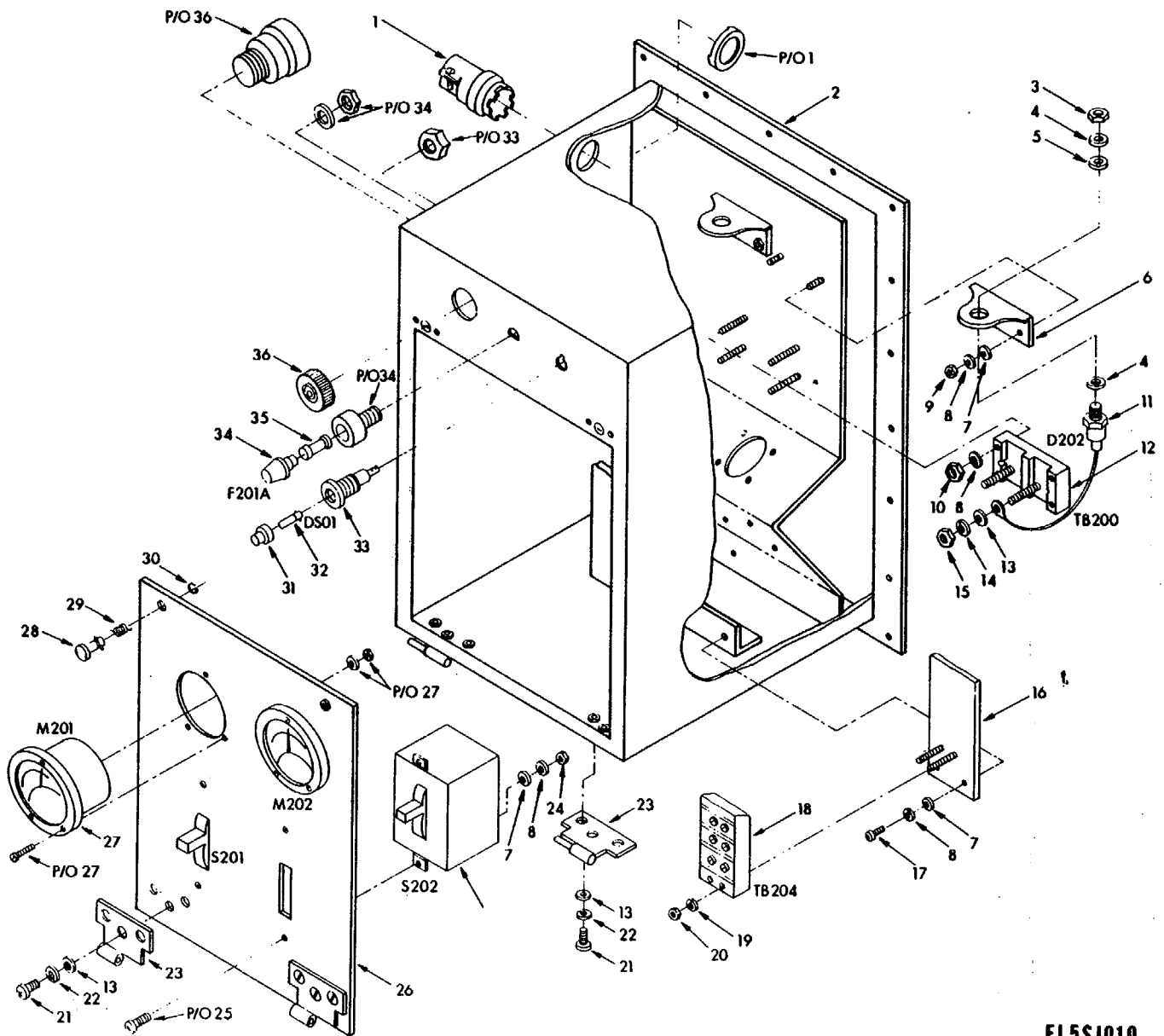

EL5SJ010

Figure 6. DC Power Distribution Box.

(1) ILLUSTRATION		(2) SMR CODE	(3) NATIONAL STOCK NUMBER	(4) FSCM	(5) PART NUMBER	(6) DESCRIPTION  <i>USABLE ON CODE</i>	(7) U/M	(8) QTY INC IN UNIT
(a) FIG NO.	(b) ITEM NO.							
C	6	31	PAOZZ	6210-00-813-6642	81349	LC12WT2		
	6	32	PANZZ	6240-00-155-7836	96906	MS25237-327		
	6	35	PAOZ	5920-00-284-9220	81349	FO28250V1A		
						GROUP 010202 DC POWER DISTRIBUTION BOX		
						LENS,LIGHT .....	EA	1
						LANP,INCANDESCENT.....	EA	1
						FUSE,CATRIDGE.....	EA	1

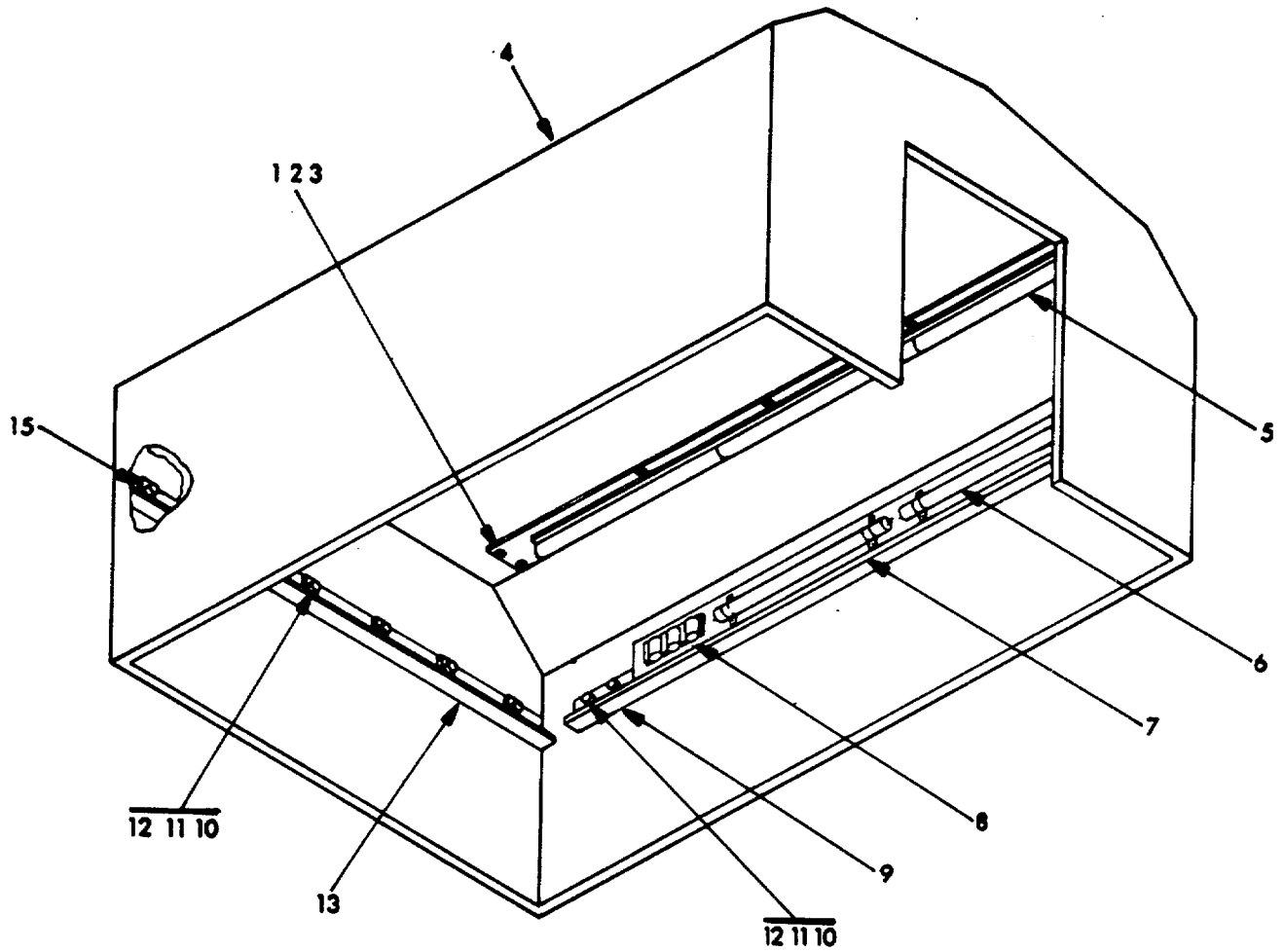

EL5SJ009

Figure 7. Top Assembly.

(1) ILLUSTRATION		(2)	(3)	(4)	(5)	(6)	(7)	(8)
(a) FIG NO.	(b) ITEM NO.	SMR CODE	NATIONAL STOCK NUMBER	FSCM	PART NUMBER	DESCRIPTION  <i>USABLE ON CODE</i>	U/M	QTY INC IN UNIT
						GROUP 010205 TOP ASSEMBLY		
7	1	PAOZZ	5305-00-984-6194	96906	MS35206-246	SCREW,MACHINE .....	EA	2
7	2	PAOZZ	5316-00-045-3294	96906	MS35338-42	WASHER,LOCK.....DJR	EA	10
7	3	PAOZZ	5310-00-765-3197	96906	MS27183-41	WASHER,FLAT.....DJR	EA	10
7	6	PAOZZ	6240-00-152-2982	08805	F15TBCW	LAMP.FLUORESCENT.....	EA	2
7	8	PAOZZ	6250-00-194-4794	91595	F52NA	STARTER,FLUORESCENT .....	EA	3



## SECTION IV

## NATIONAL STOCK NUMBER AND APRT NUMBER INDEX

TM 11-5805-693-20P-1

STOCK NUMBER	FIGURE NO.	ITEM NO.	STOCK NUMBER	FIGURE NO.	ITEM NO.
5995-00-041-3535	5	2	5995-00-241-7489	5	1
5310-00-045-3299	7	2	5920-00-284-9220	6	35
6140-00-059-3528	1	20	5995-00-319-8886	5	1
5965-00-069-8885	1	16	5995-00-441-9139	5	1
5995-00-102-1494	5	1	4210-00-555-8837	1	8
5995-00-113-0969	5	2	5995-00-717-9887	5	2
5805-00-124-8678	1	28	6230-00-729-9614	1	6
6130-00-133-5879	1	2	5310-00-765-3197	7	3
5995-00-134-7159	1	51	6210-00-813-6642	6	31
6240-00-152-2982	3	18	5305-00-984-6194	7	1
6240-00-152-2982	7	6	5995-00-998-0924	5	2
6240-00-155-7836	6	32	5830-01-008-3126	1	32
6630-00-171-4467	1	12	5805-01-032-1694	1	1
7920-00-178-8315	1	10	5995-01-096-4562	5	1
6250-00-194-4794	3	9	5120-01-110-9193	2	26A
6250-00-194-4764	7	8	5120-01-127-8248	2	25
5975-00-224-5260	2	13			

FSCM	PART NUMBER	FIGURE NO.	ITEM NO.	FSCM	PART NUMBER	FIGURE NO.	ITEM NO.
81348	AAC295CL2SIZE2	1	48	80063	SC-C-865810-1	5	1
91595	FS2NA	7	8	80063	SC-C-865810-2	5	1
81349	FO2B250V1A	6	35	80063	SC-C-865810-4	5	1
08805	F15T8CW	3	18	80063	SC-C-865810-5	5	1
08805	F15T8CW	7	6	80063	SC-C-865811-1	5	2
81348	GGGW631TYPEICLI SIZE 8	1	14	80063	SC-C-865811-2	5	2
81348	GGT258CLISTYLEB	1	12	80063	SC-C-865811-3	5	2
80058	H-182/PT	1	16	80063	SC-C-931547	4	3
81349	LC12WT2	6	31	80063	SC-D-539505	2	26A
80058	LS-147F/FI	1	32	80063	SC-D-681425	1	5
81349	MILH52204TYPEI	1	19	80063	SC-D-931238	2	25
96906	MS25237-327	6	32	80063	SC-D-931429	1	8
96906	MS27183-41	7	3	80063	SCC539500-2	1	47
96906	MS35206-246	7	1	80063	SM-D-352124	1	51
96906	MS35338-42	7	2	80063	TA-838/TT	1	28
96906	MS75047-1	1	20	81348	WS755TYPE1CLASSB	3	9
80058	MX-148/G	2	13	94322	095022101	1	10
70674	PJ-763	5	1	32572	12106-7	1	6
80058	PP-6224/U	1	2	13499	5361-2073-000	5	2
80058	SB-3614(V)/TT	1	1	07395	775090A0137-1117	1	17

By Order of the Secretary of the Army:

**E.C. MEYER**  
*General, United States Army*  
*Chief of Staff*

*Official*

**ROBERT M. JOYCE**  
*Major General, United States Army*  
*The Adjutant General*

\*U.S. GOVERNMENT PRINTING OFFICE: 1994 - 300-421/82085

RECOMMENDED CHANGES TO EQUIPMENT TECHNICAL PUBLICATIONS

 <p style="font-size: small; margin: 0;"><i>THEN...JOT DOWN THE DOPE ABOUT IT ON THIS FORM. CAREFULLY TEAR IT OUT, FOLD IT AND DROP IT IN THE MAIL.</i></p>		SOMETHING WRONG WITH PUBLICATION	
		FROM: (PRINT YOUR UNIT'S COMPLETE ADDRESS)	
		DATE SENT	
PUBLICATION NUMBER		PUBLICATION DATE	PUBLICATION TITLE
IN THIS SPACE, TELL WHAT IS WRONG AND WHAT SHOULD BE DONE ABOUT IT.			
BE EXACT PIN-POINT WHERE IT IS			
PAGE NO.	PARA-GRAPH	FIGURE NO.	TABLE NO.
PRINTED NAME, GRADE OR TITLE AND TELEPHONE NUMBER		SIGN HERE	

